

# SUPERCRITICAL WATER HYDROTHERMAL SYNTHESIS OF METAL OXIDE NANOPARTICLES

**Paul A. Hamley<sup>\*a</sup>, Paul Blood<sup>b</sup>, Edward Evans<sup>a</sup>, Barry Azzopardi<sup>b</sup>, Ed Lester<sup>b</sup>,  
Martyn Poliakoff<sup>a</sup>.**

<sup>a</sup> School of Chemistry, University of Nottingham, Nottingham NG7 2RD, UK;

<sup>b</sup> School of Chemical, Environmental and Mining Engineering, University of Nottingham.

[Paul.Hamley@nottingham.ac.uk](mailto:Paul.Hamley@nottingham.ac.uk)

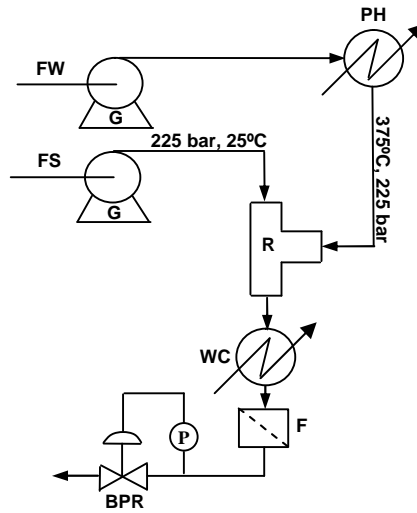
<http://www.nottingham.ac.uk/supercritical>

Fax 0044 (0) 115 951 3058

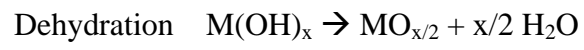
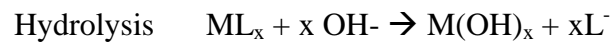
## INTRODUCTION

Supercritical Water (scH<sub>2</sub>O) offers an environment which facilitates the hydrolysis and oxidation of metal salts such as nitrates, carbonates, acetates and formates to their corresponding nano-particulate metal oxides (or metal particles under certain conditions), by mixing supercritical water with a stream of metal salt in an aqueous solution [1]. This is a relatively new and promising development since it can be also carried out in a continuous reactor.

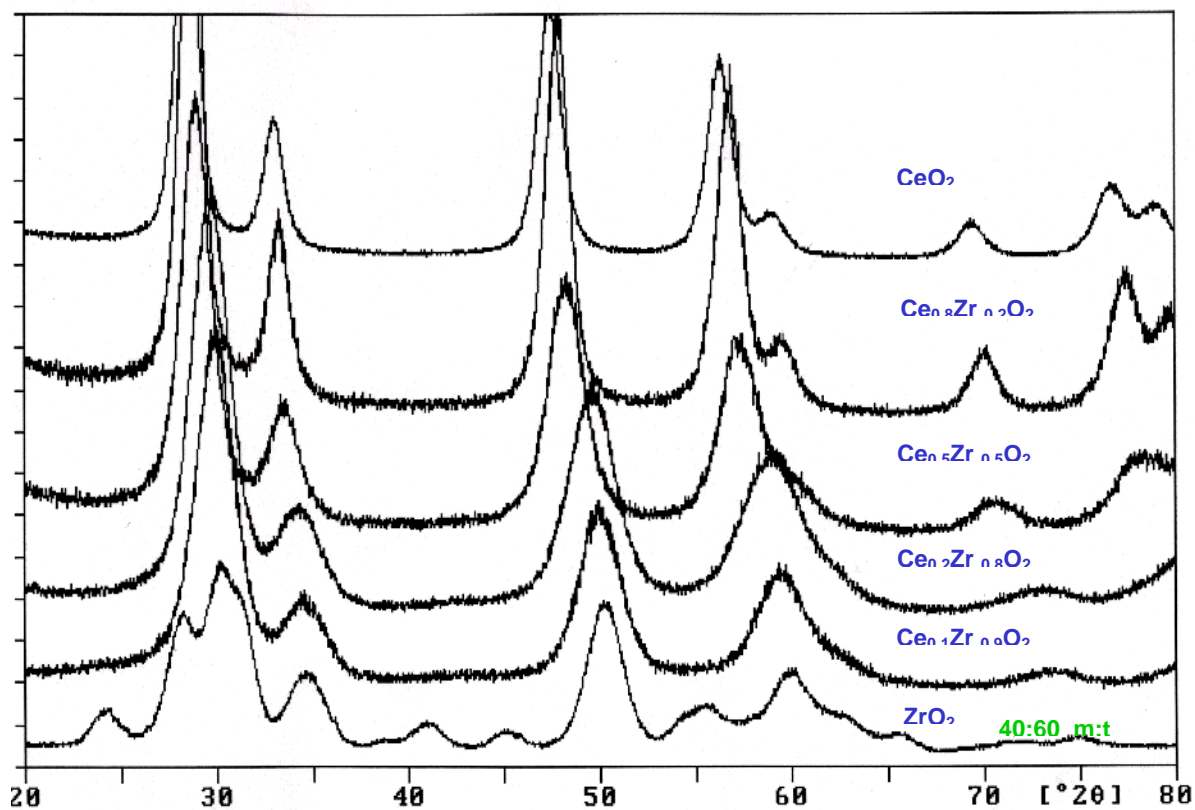
The production of nano-particulates in supercritical water is of potential industrial importance since, in some processes; scH<sub>2</sub>O can be used as a replacement for expensive or toxic solvents. At temperatures of 350-500°C utilised in SCW oxidation, a more energy-efficient route to some materials is offered compared to conventional processes of grinding and calcining. A major advantage of synthesis in supercritical water over conventional techniques is the possibility to produce intimately mixed metal oxides from an aqueous mixture of two metal salts. As reported previously [2-4], an aqueous solution of two or more metal salts is prepared and pumped cold into a stream of near-critical or supercritical water (Figure 1). Hydrolysis, followed by dehydration (Scheme 1) then occurs, resulting in the production of intimately mixed metal oxides. Figure 2 shows the result of varying the relative amounts of two metal precursors, Cerium ammonium nitrate and zirconium acetate. Ceria-Zirconia is used as a 3-way automotive catalyst (CO, hydrocarbon oxidation, NO<sub>x</sub> reduction) due to its ability to store and release oxygen.



**Scheme 1**

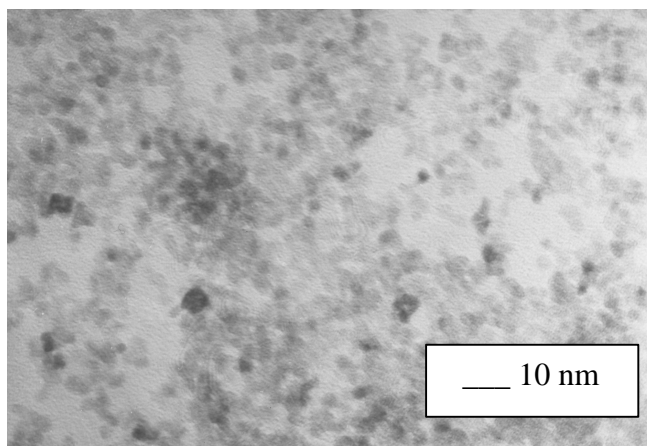
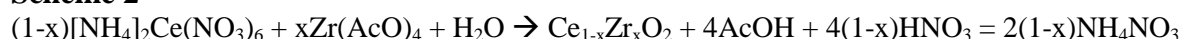


**Figure 1:** Flow diagram of the continuous supercritical reactor system used by the Clean Technology Group. This equipment is used for various supercritical reactions including metal oxide and mixed metal oxide nano-particle production. Key: FW – water feed, FS – aqueous metal salt feed, G – Gilson HPLC Pump, PH – preheater, R – continuous reactor, WC – water cooling, F – 0.5µm Filter, BPR – Tescom back pressure regulator, P – pressure transducer.



**Figure 2** Powder X ray diffractograms of intimately mixed single phase Ce/Zr oxide showing the effect of changing the ratio of ceria precursor to zirconia precursor. A single mixed oxide phase is present.

**Scheme 2**



**Figure 3:** Transmission Electron Micrograph (TEM) of  $\text{Ce}_{0.5}\text{Zr}_{0.5}\text{O}_2$  showing a narrow size distribution of particles in the 3-5nm range.

### **The Effect of Counter Ions**

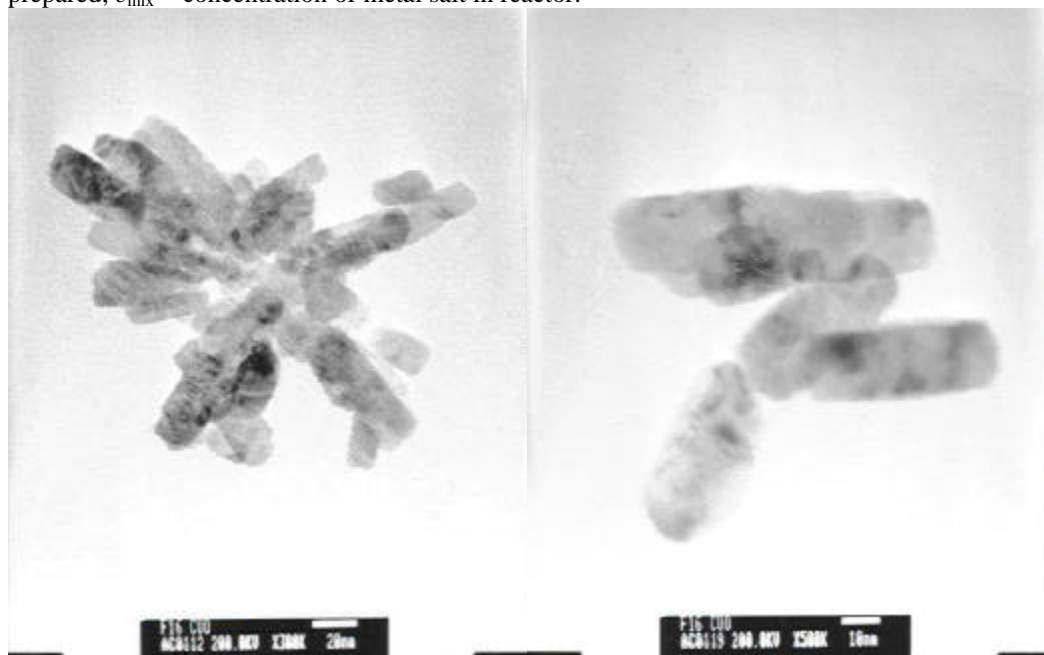
Using 18M $\Omega$  distilled water which has not been de-aerated, most metal salts produce oxides under scH<sub>2</sub>O conditions. However, metals which are easily reduced may produce metal particles; this can be influenced by the choice of counter ion. This has been found in the case of copper, where Cu, Cu<sub>2</sub>O and CuO can be produced, depending on the counter ion and conditions [5] (Table 1). The use of an organic counter ion, such as formate which can act as a reducing agent leads to a mixture of Cu, Cu<sub>2</sub>O and CuO, whereas when using a copper carbonate precursor only CuO has been observed (Table 1).

The acetate ion is known to undergo oxidation in water at around 200°C, competition for oxygen between Cu and acetate leads to Cu<sub>2</sub>O formation. In the case of Copper formate, decomposition of the formate ions to CO<sub>2</sub> and H<sub>2</sub> can occur (gases have been detected from the decomposition of formate in separate experiments). Copper formate can be completely oxidised in the presence of excess O<sub>2</sub>, using a solution of hydrogen peroxide, giving excess dissolved oxygen in supercritical water.

**Table 1:** Products obtained using different counter ions.

Precursor	Product	$d$ /nm	$T_M$ /°C	$T_H$ /°C	$F_w$ /ml min <sup>-1</sup>	$F_{MS}$ /ml min <sup>-1</sup>	$F_{tot}$ /ml min <sup>-1</sup>	$\rho_w$ /g cm <sup>-3</sup>	$t_R$ /min	$c_{MS}$ /mol l <sup>-1</sup>	$c_{mix}$ /mol dm <sup>-3</sup>
Cu(Ac) <sub>2</sub>	Cu <sub>2</sub> O	300-500	190	385	5	3.5	8.5	0.451	0.53	0.212	0.087
	CuO	24						0.215	0.25		
Cu(Fo) <sub>2</sub>	Cu	90-100	225	453	5	3.5	8.5	0.109	0.13	0.110	0.045
	Cu <sub>2</sub> O	80-100									
	CuO	40-50									
CuCO <sub>3</sub>	CuO	17	185	396	5	5	10	0.167	0.167	0.065	0.033

$d$  = particle diameter, determined from PXD data by the Scherrer equation;  $T_M$  = mixing temperature at T-piece;  $T_H$  = reactor temperature;  $F_w$  = rate of water flow;  $F_{MS}$  = rate of metal-salt flow;  $F_{tot}$  = total flow rate through reactor;  $\rho_w$  = density of water at reaction conditions;  $t_R$  = residence time;  $c_{MS}$  = concentration of metal salt prepared;  $c_{mix}$  = concentration of metal salt in reactor.

**Figure 4a,b**

Transmission Electron Micrographs of CuO particles at (a) x300k, (b) x500k magnification. The size bar is 20nm (a) and 10nm (b) respectively.

In contrast to the spherical Ce/ZrO<sub>2</sub> particles, these have an aspect ratio of around 3.

### Optimisation of Mixing

Whilst chemists have investigated the effects of solution pH, metal salt concentration, and other factors such as temperature and pressure on the morphology and size distribution of fine metal oxide particles, chemical engineers have been addressing the problems associated with mixing within the reactor. The way in which the supercritical water mixes with the metal salt solution is of considerable importance since the mixing regime will inevitably affect the quality and quantity of product. Therefore, developing a better understanding of the mixing that occurs within these continuous reactors is crucial for process control and optimisation.

The mixing geometry used in the initial reactor consisted of the two flows meeting at a simple T-piece (Figure 1). Ideally, the metal salt solution should be heated rapidly where it contacts the supercritical water stream, but in practice, conduction of heat through the metal tubing resulted in precipitation of the metal salt which blocked the metal salt inlet. A partial solution was effected by surrounding the incoming cold tubing with a water cooling jacket. The problem is dependent on the material, and is thought to be related to particle nucleation and growth rates.

In order to investigate the problem of blockages in the mixing area, studies began using a 'Pseudo-reactor' designed to mimic the fluid dynamics occurring in the actual supercritical reactor. This is achieved at ambient conditions using two fluids that have been carefully selected so that they exhibit a similar ratio of inertia to viscous forces to that present in the actual supercritical reactor. Methanol (Pseudo-scH<sub>2</sub>O) was chosen to represent scH<sub>2</sub>O whereas the aqueous metal salt stream was modelled by a 40 % w/w aqueous sucrose solution (Pseudo-metal salt). Inlet flowrates were set such that the resultant Reynolds numbers matched those used in the supercritical rig. All the results obtained were enhanced and quantified using our two-dimensional image analysis technique known as Light Adsorption Imaging (LAI). This technique is based on the adsorption of light by a dyed fluid, the output being an accurate and quantitative 'concentration map'. Figure 5 shows the concentration map for the T-piece at typical reaction conditions. It can be observed that the low density near-critical water (represented by the dark horizontal band) runs along the arm of the T piece (from right to left), turns the corner and moves up into the slowly descending sugared water (cold metal salt solution) due to its buoyancy. The mixing distribution is very poor for this configuration.

Using a combination of Image Analysis and Computational Fluid Dynamics [7-8], modelling work to optimise the geometry and orientation of the reactor has led to analysis of several different possible mixing geometries and orientations. A novel mixing geometry has been constructed, consisting of vertically oriented concentric tubes, the supercritical water being injected downwards into an upflow of cold metal salt (Figure 6).

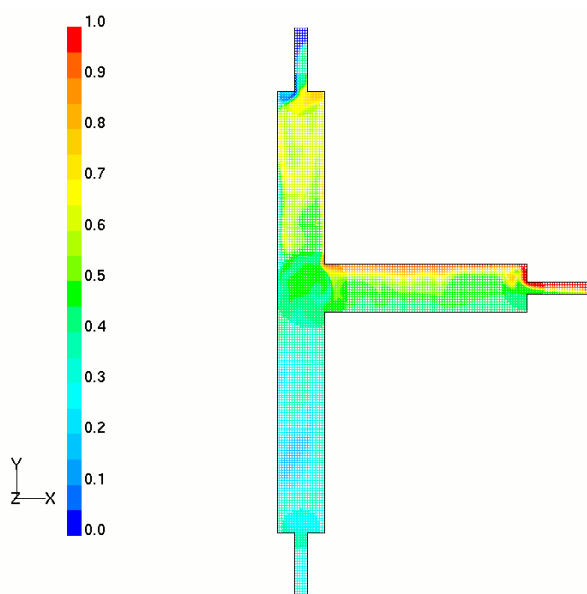
Good mixing is ensured by a conical insert, forcing both flows together in a narrow annular ring. This arrangement has been found to be very reliable, and can produce a range of nano-particulate metals/metal oxides continuously without problems such as particle build-up and blocking, leading to particle sizes of less than 10nm.

## CONCLUSION

Hydrothermal synthesis is a versatile method for production of metal oxides, allowing both controlled preparation of intimately mixed single phase mixtures and a degree of control over morphology and oxidation state.

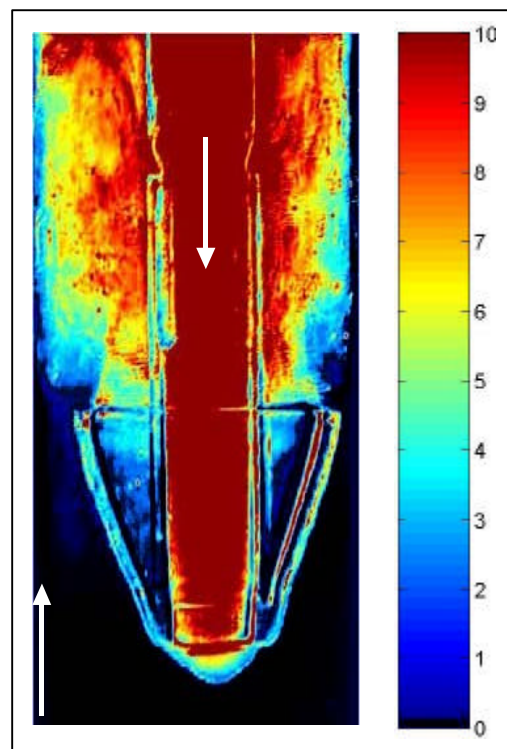
A robust and effective mixing piece has been designed, which performs well on difficult substrates such as copper oxide, which typically produces larger particles and is prone to blockage.

**ACKNOWLEDGEMENTS:** We thank Dr D. Giddings for help with CFD calculations, Dr A. Cabanas for TEM, Dr T. Ilkenhans, Dr J.A. Darr, the workshop staff of SChEME and the School of Chemistry, the EPSRC and Johnson Matthey for support.



**Figure 5**

Computational Fluid Dynamics Image based on data captured by video. Dyed sugared water enters the mixing T from above, methanol (representing  $scH_2O$ ) from the right. The low density fluid runs along the upper surface of the horizontal arm before turning upwards, slow rotational mixing is observed. The lighter shades in the upper arm reveal that considerable amounts of the low density fluid move into this region, contributing to blocking the narrow inlet of metal salt solution in the reactor. The vertical scale represents concentration of methanol.



**Figure 6**

Processed video image showing model of concentric pipe mixing arrangement. The low density fluid (methanol representing  $scH_2O$ ) enters through the inner pipe from above and flows across the surface of the cone, being forced to mix with the cool dense liquid travelling upwards as the two fluids are forced through a narrow ring. Turbulent conditions are observed indicating better mixing.

(The vertical scale gives dye concentration in ppm)

## REFERENCES:

- [1] Adschiri, T., Kanazawa, K., and Arai, K., "Rapid and continuous hydrothermal crystallization of metal oxide particles in  $sc$  water", *J. Am. Ceram. Soc.*, **1992**, 75, 1019.

- [2] Cabañas, A., Darr, J. A., Lester, E., Poliakoff, M., *J. Mat. Chem.*, **2001**, 11, p.561.
- [3] Cabañas, A., Darr, J. A., Lester, E., Poliakoff, M., *Chem. Commun.*, **2000**, p.901.
- [4] Cabañas, A., Poliakoff, M., *J. Materials Chem.*, **2001**, Vol 11, p.1408.
- [5] Ilkenhans, T., Evans, E., Darr, J.A., Cabanas, A., Blood, P.J., Lester, E., Jones, I., Hamley, P.A., Poliakoff, M. Manuscript in preparation
- [6] Adschiri, T., Takami, S., Umetsu, M., and Tsukada, T., *6<sup>th</sup> International Symposium on Supercritical Fluids*. Versailles, France, 28-30 April 2003.
- [7] Denyer, J.P., Lester, E., Hamley, P.A., Poliakoff, M., Giddings, D., Blood, P.J., and He, F. *8<sup>th</sup> Meeting on Supercritical fluids*, 14 – 17 April 2002, Bordeaux, France.
- [8] Blood, P. J., Denyer, J. P., Lester, E., Poliakoff, M., Hamley, P. A. and Giddings, D., *4<sup>th</sup> symposium on high pressure technology and chemical engineering*, Venice, Italy, Sept 2002.